

SECTION A-A

SLIDE ROD
MUST BE GREASED

INSIDE OF BASE
MUST BE SHOTBLAST
CLEAN AND FREE OF
ALL SAND, DEBRIS
& SHAVINGS

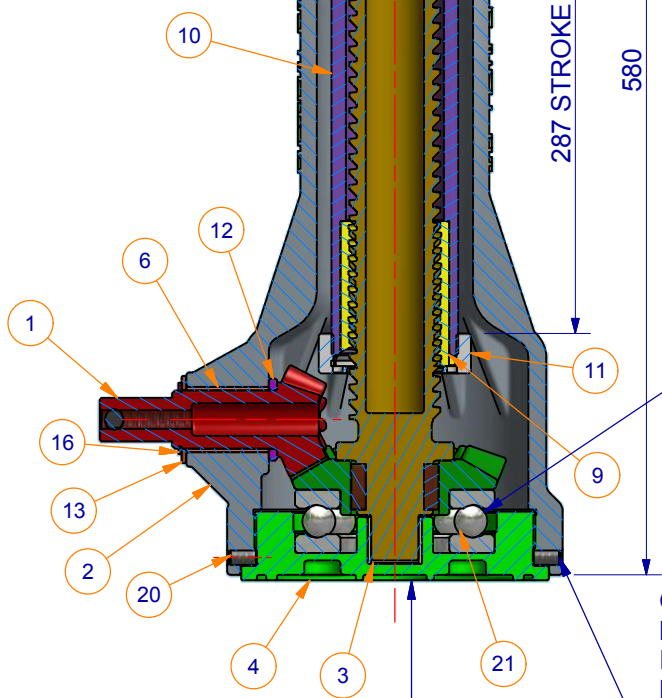

GREASE THE BEARING

GRUB SCREWS
MUST BE DRILLED
IN THE RIGHT
PLACE ON FINAL
ASSEMBLY

SCREW CAP IN
TILL IT BOTTOMS OUT

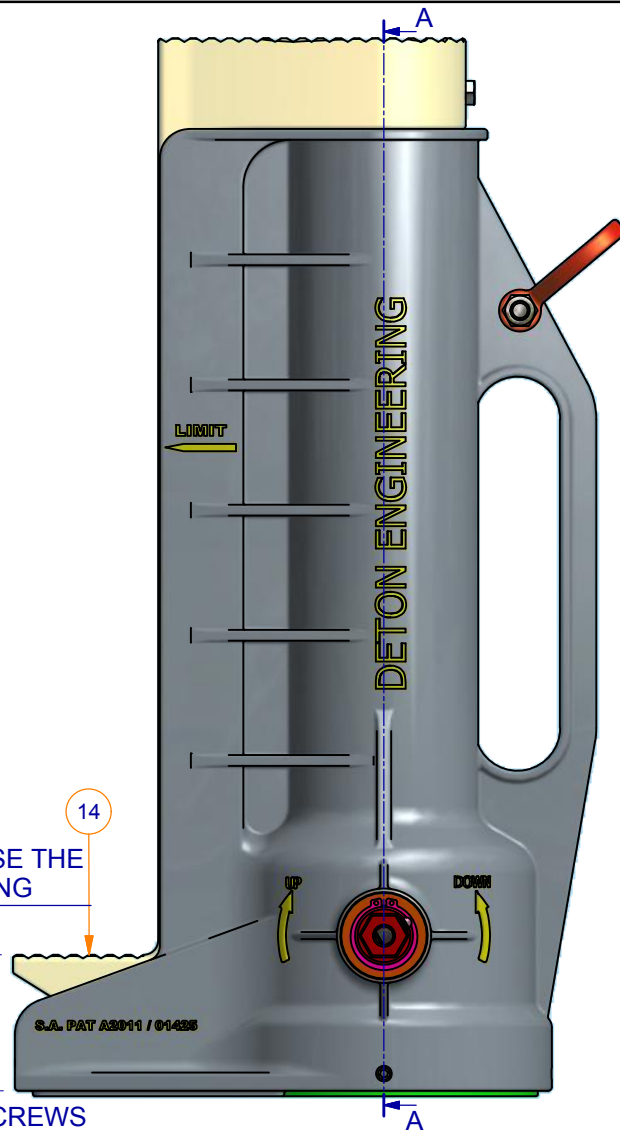

SECTION B-B

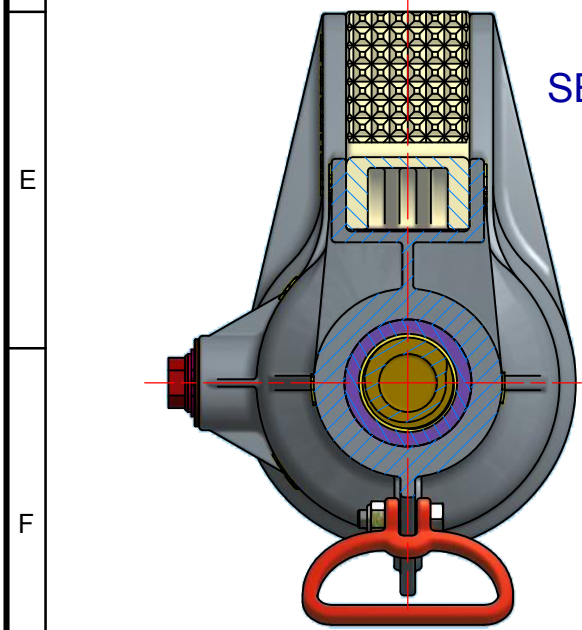
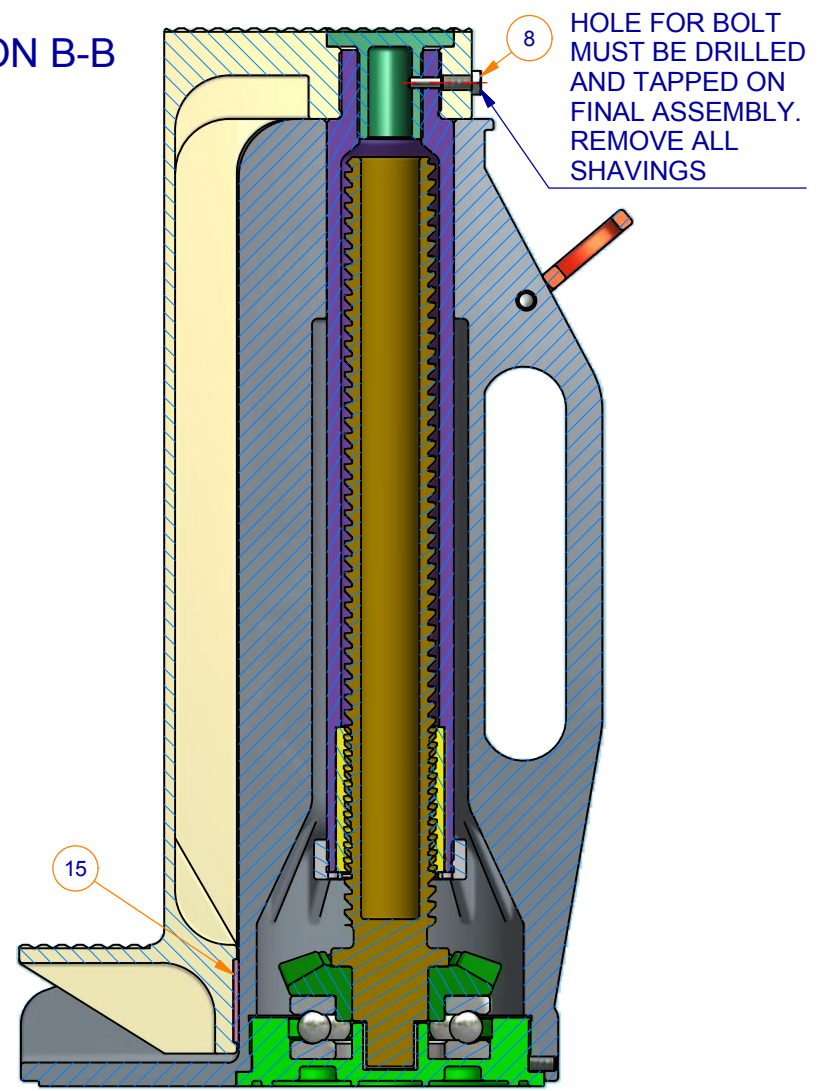

SECTION C-C

ITEM	DESCRIPTION	REQD	DRWG NO.	MATERIAL	MASS	REMARKS
21	THRUST BEARING	1		Generic	0.17 kg	ACCOR 51312
20	M8 x 15 GRUB SCREW	3		High Tensile Steel	0.01 kg	
19	M10-NYLOCK	1		Generic	0 kg	
18	M10 x 6 BALL DETENT	1		Mild Steel	0.01 kg	
17	M10 BOLT x 40	1		Mild Steel	0.04 kg	
16	32-OUTSIDE CIRCLIP	1		Generic	0 kg	DIA 32 SHAFT / CODE 0320
15	WEAR PAD	1	10TSJ-019	ABS Plastic	0.01 kg	
14	TOE 2 RIBS	1	10TSJ-018	EN19	10.1 kg	
13	THRUST WASHER	1	10TSJ-017	Aluminum Bronze	0.01 kg	
12	SPACER	1	10TSJ-016	Aluminum Bronze	0.01 kg	
11	SLIDE ROD NUT	1	10TSJ-020	Mild Steel	0.05 kg	
10	SLIDE ROD	1	10TSJ-015	EN19 con V	5.34 kg	
9	NUT	1	10TSJ-014	Aluminum Bronze	0.24 kg	
8	M8 BOLT x 35 MACHINED	1	10TSJ-013	Mild Steel	0.02 kg	
7	CARRY HANDLE	1	10TSJ-021	Aluminum	0.07 kg	
6	BUSH	1	10TSJ-012	Aluminum Bronze	0.03 kg	
5	BOLT	1	10TSJ-011	Cast Steel	0.49 kg	
4	BASE CAP	1	10TSJ-010	Cast Steel	2.95 kg	
3	BASE BUSH	1	10TSJ-009	Aluminum Bronze	0.01 kg	
2	BASE	1	10TSJ-008	Aluminum	9.17 kg	
1	BEVEL GEAR ASSEMBLY SPLIT	1	10TSJ-002		5.72 kg	

TOLERANCE	MACHINE	FAB
0 TO 100	± 0.10	± 0.50
100 TO 500	± 0.20	± 1.00
500 TO 1000	± 0.50	± 1.50
1000 PLUS	± 1.00	± 2.00

THE ARTICLE IN THIS DRAWING IS THE SUBJECT OF PATENT PROTECTION. NO REPRODUCTION OR PUBLICATION OF THIS DRAWING MAY BE MADE WITHOUT THE PRIOR CONSENT OF THE OWNER, NOR MAY ANY ARTICLE BE MADE OR ASSEMBLED FROM THIS DRAWING WITHOUT SUCH CONSENT. ALL RIGHTS RESERVED UNDER THE COPYRIGHT ACT.

FILE NAME: GENERAL ASSEMBLY.idw

TITLE: GENERAL ASSEMBLY

10 TON STEPTON JACK

DRAWING NO. 10TSJ-001

P.O. Box 123920
Alrode 1451
Telephone +27 (11) 908 1922
Telefax +27 (11) 864 5386
6 Barium Str. Alrode Ext 7

DESIGNED BY: A. HARRIS

DATE CREATED: 03 / 07 / 2013

SCALE: 1 OF 3 SHEET OF 3 A3

A

B

C

Φ

D

E

F

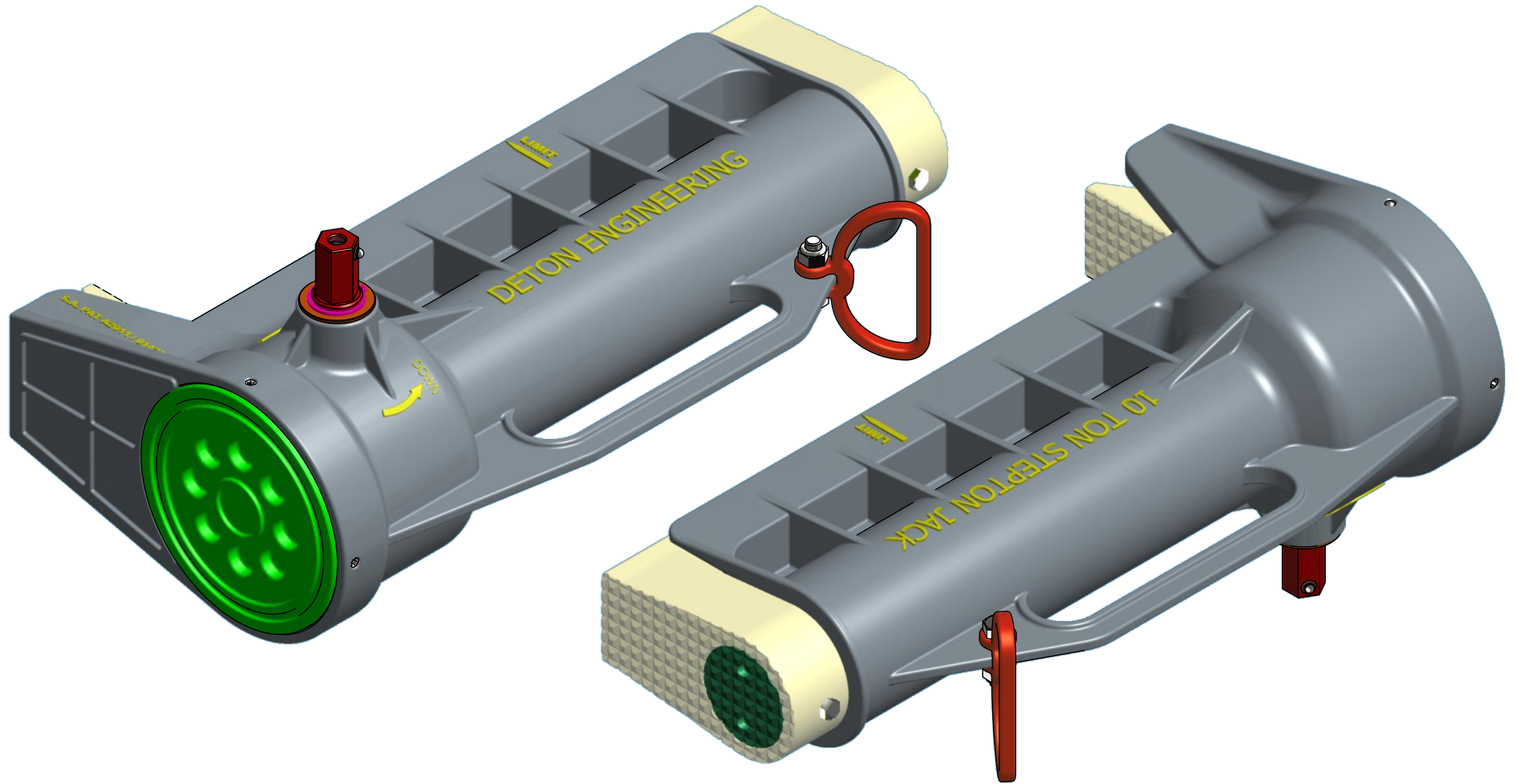

TOLERANCE	MACHINE	FAB
0 TO 100	± 0.10	± 0.50
100 TO 500	± 0.20	± 1.00
500 TO 1000	± 0.50	± 1.50
1000 PLUS	± 1.00	± 2.00

DETON
ENGINEERING (Pty) Ltd

FILE NAME
GENERAL ASSEMBLY.idw

THE ARTICLE IN THIS DRAWING IS THE SUBJECT OF PATENT PROTECTION. NO REPRODUCTION OR PUBLICATION OF THIS DRAWING MAY BE MADE WITHOUT THE PRIOR CONSENT OF THE OWNER, NOR MAY ANY ARTICLE BE MADE OR ASSEMBLED FROM THIS DRAWING WITHOUT SUCH CONSENT. ALL RIGHTS RESERVED UNDER THE COPYRIGHT ACT

TITLE:
GENERAL ASSEMBLY

10 TON STEPTON JACK

DRAWING NO. **10TSJ-001**

P.O. Box 123920
Alrode 1451
Telephone +27 (11) 908 1922
Telefax +27 (11) 864 5386
6 Barium Str. Alrode Ext 7

DESIGNED BY **A. HARRIS**

DATE CREATED **03 / 07 / 2013**

SCALE: SHEET **2** OF **3** **A3**

1

2

3

4

Φ

5

6

7

8

A

B

C

⌀

D

E

F

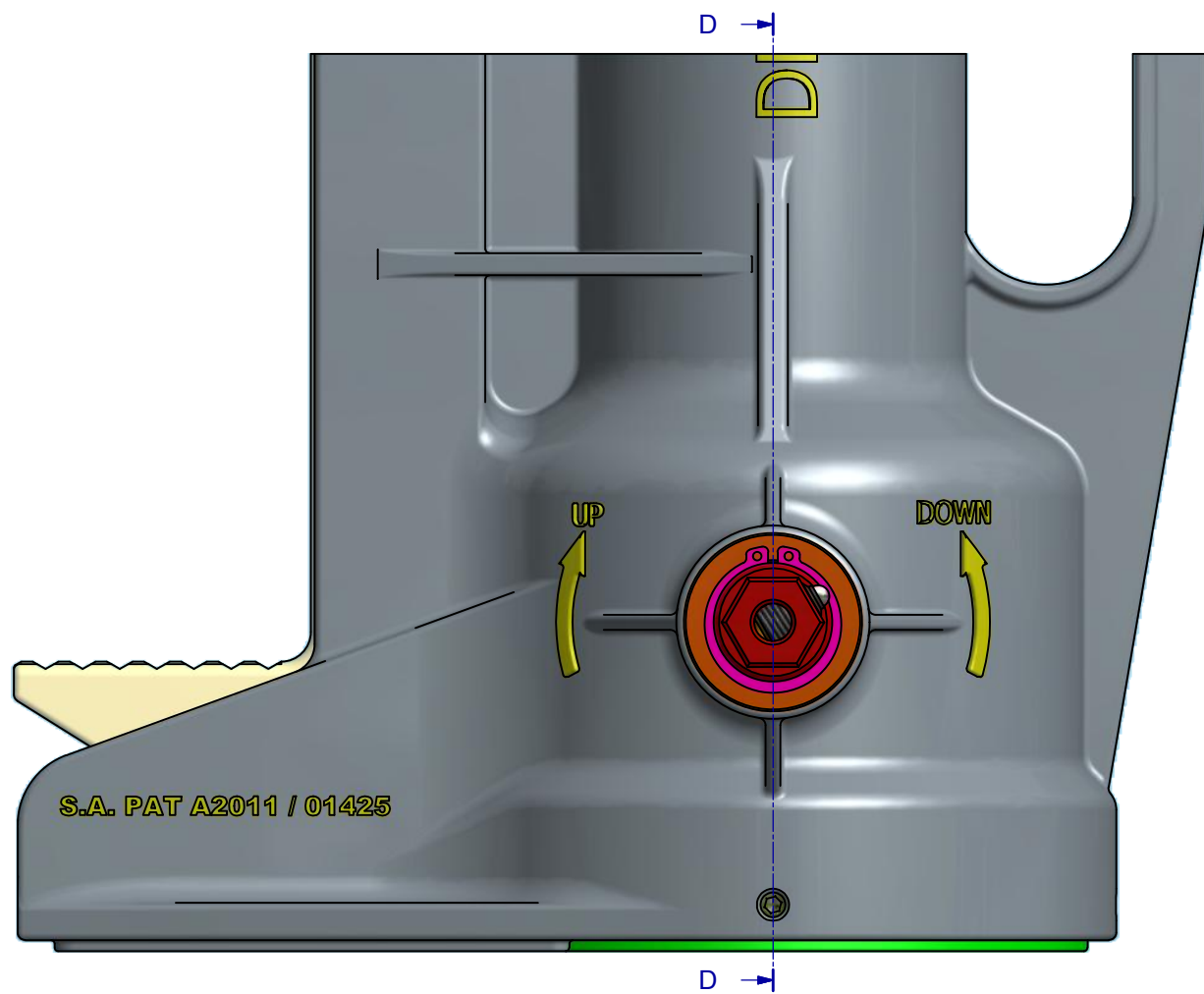

SECTION D-D

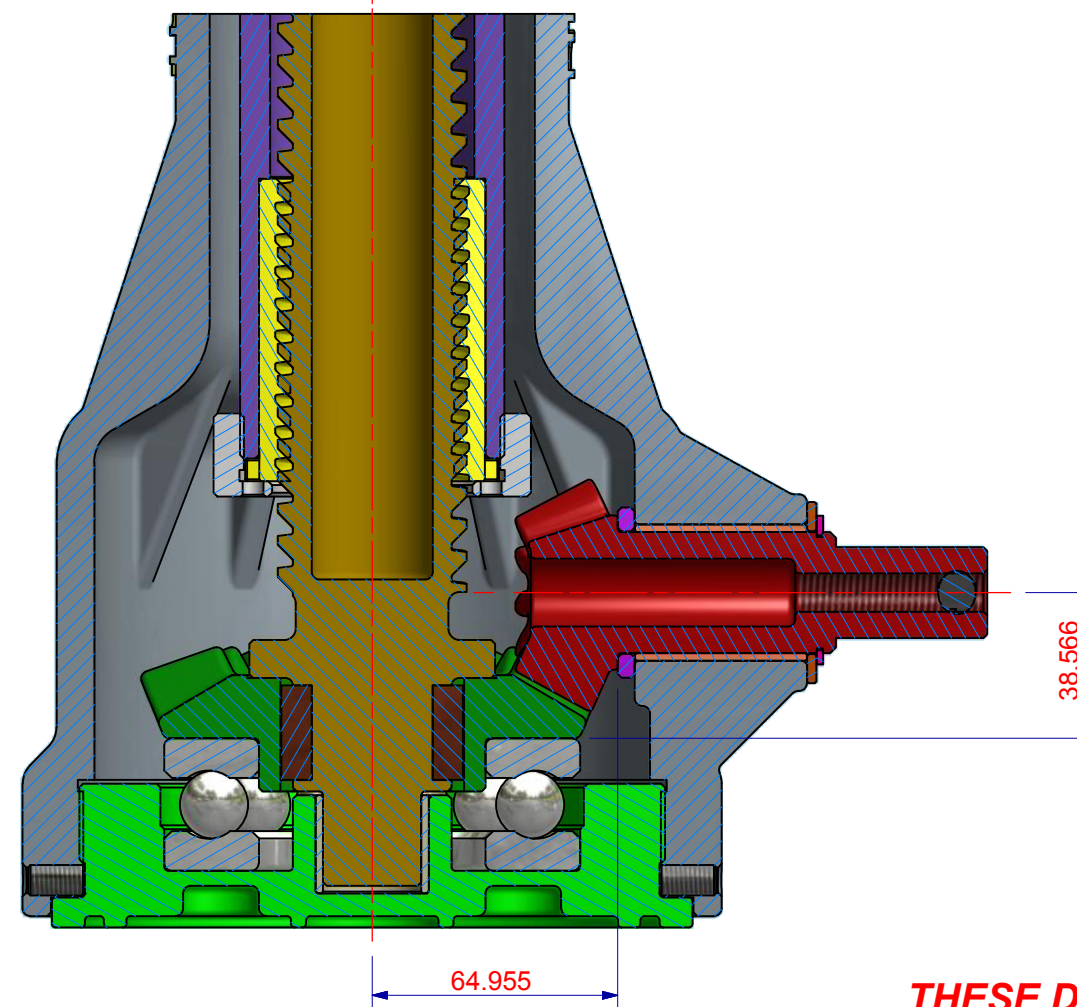

THESE DIMENSIONS ARE CRITICAL AND MUST BE STUCK TOO IN ORDER FOR GEARS TO MESH PROPERLY

TOLERANCE	MACHINE	FAB
0 TO 100	± 0.10	± 0.50
100 TO 500	± 0.20	± 1.00
500 TO 1000	± 0.50	± 1.50
1000 PLUS	± 1.00	± 2.00

FILE NAME
GENERAL ASSEMBLY.idw

THE ARTICLE IN THIS DRAWING IS THE SUBJECT OF PATENT PROTECTION. NO REPRODUCTION OR PUBLICATION OF THIS DRAWING MAY BE MADE WITHOUT THE PRIOR CONSENT OF THE OWNER, NOR MAY ANY ARTICLE BE MADE OR ASSEMBLED FROM THIS DRAWING WITHOUT SUCH CONSENT. ALL RIGHTS RESERVED UNDER THE COPYRIGHT ACT.

TITLE:
GENERAL ASSEMBLY
10 TON STEPTON JACK

DRAWING NO.
10TSJ-001

P.O. Box 123920
Alrode 1451
Telephone +27 (11) 908 1922
Telefax +27 (11) 864 5386
6 Barium Str. Alrode Ext 7

DESIGNED BY
A. HARRIS

DATE CREATED
03 / 07 / 2013

SCALE:
3 OF 3 **A3**

1

2

3

4

⌀

5

6

7

8